

## Common Applications

The flexibility of the transceivers makes them ideally suited for:

- Earth stations where L-Band IF products are being integrated into a 70/140 MHz IF infrastructure
- Reconfigurable multi-band requirements that are typically found in transportable / flyaway type installations

## Introduction

The RF marketplace has been transitioning from traditional 70/140 MHz IF-based networks to systems using L-Band (950 to 2000 MHz) for the modem/RF equipment link. The MBT-4000 and MBT-4000B Multi-Band RF Transceivers are designed to perform C, X, Ku or Ka RF to L-Band down conversion and L-Band to C, X or Ku RF up conversion. The MBT-4000 supports two independent converter modules. The MBT-4000B supports one up converter module and also provides the bias, reference, and monitoring of one LNB.

The transceivers also provide the following features:

- RF band switching in minimal time without requiring tools
- Minimal cost for a complete system including spares
- Easy expansion for providing a redundant system or other frequency bands
- Rugged construction for mobile and transportable applications
- Automatic band identification for the BUC, BDC, and antenna feed (if the feeds provide an identifying connector)
- Meets or exceeds MIL-STD-188-164A
- Low phase noise
- No spectral inversion
- 10 dB gain adjustment
- Auto band sensing capability
- Easy system status verification via LEDs located behind a removable cover
- 1:1 redundant up and down conversion which can be "Chain switched" with external amplifiers and LNA/LNBs

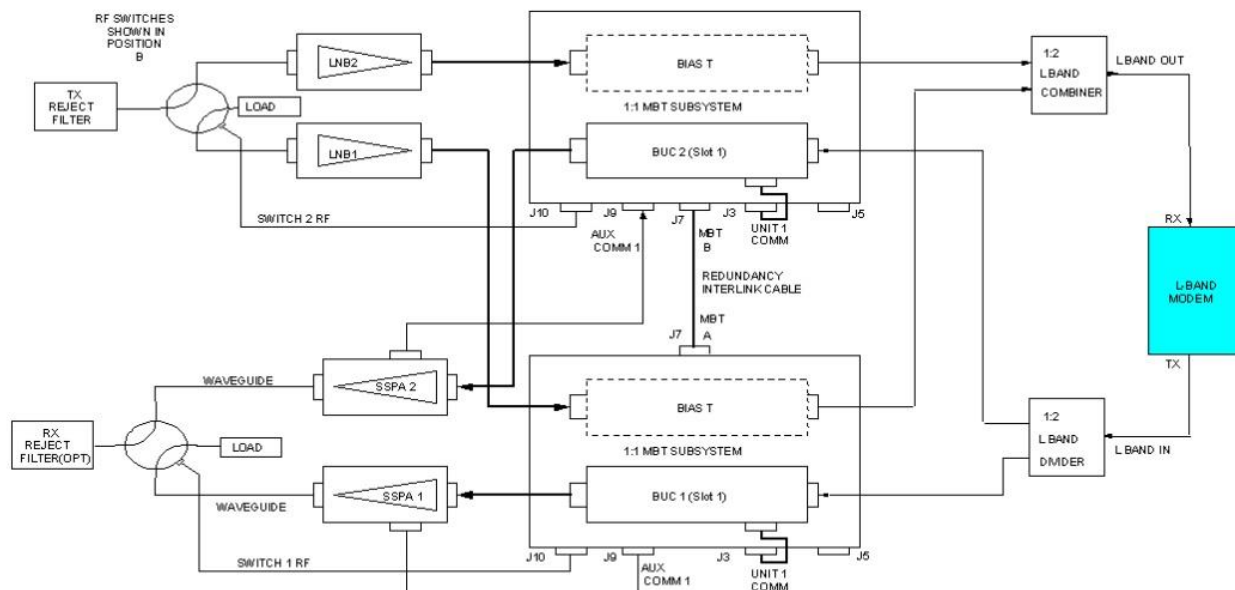

Typical TX/RX Redundant System

## Specifications

### BUC-4000 Block Up Converter ODU

Input Frequency Range	950 to 2000 MHz (C, X, Ku)
Output Frequency By Model	
BUC-4000C	5850 – 6650 MHz, 5850 to 6725MHz
BUC-4000X	7900 – 8400 MHz
BUC-4000Ku	13.75 – 14.50 GHz
Input/Output Impedance	50 Ω
Input Return Loss	15 dB minimum
Output Return Loss	18 dB minimum
Input Connector	Type – N, female
Output Connector	N, Female (C-, X-, and Ku-Band)
Gain(nominal at minimum attenuation)	15 dB C-, X -Band 18 dB Ku-Band
User Attenuation Range	0 to 10 dB
Output Power, P1dB	+10 dBm minimum
Third Order Intercept	+20 dBm minimum
Carrier Spurious	-60 dBc
Non-Carrier Spurious	-60 dBm

### Environmental and Physical

Operating Temperature:	
ODU: BUC-4000	-40° to +50°C (-40° to 122°F)
IDU: LBC-4000	-10° to +50°C (14° to 122 °F)
Operating Humidity	5 to 95 non-condensing
Ingress Protection	Designed for IP-66 (Dust tight, strong water jets)
Operating Altitude	10,000 ft above sea level
Non-Operating Temperature:	
ODU: MBT-4000	-50° to +71°C (58° to 160°F)
Prime Power	90 to 260 VAC, 47 to 63 Hz
Size	Refer to the manual
External Reference Input	Either 5 or 10 MHz ± 5 dBm optional
Frequency Stability	1 x 10 <sup>-9</sup> /day, 1x10 <sup>-7</sup> /year 40° to +55°C 1 x 10 <sup>-8</sup> /Temperature

### BDC-4000 Block Down Converter ODU

Input Frequency By Model	
BDC-4000C	3400 to 4200 MHz
BDC-4000X	7250 to 7750 MHz
BDC-4000K	10.95 to 12.75 GHz
Output Frequency Range	950 to 2000 MHz
Input/Output Impedance	50 Ω
Input Return Loss	18 dB minimum
Output Return Loss	15 dB minimum
Input Connector	N, Female (C-, X-, and Ku-Band)
Output Connector	N, Female
Gain	15 dB nominal at minimum attenuation
User Attenuation Range	0 to 10 dB, in 0.25 dB steps (0.1 dB opt)
Output Power, P1dB	+ 12 dBm minimum
Third Order Intercept	+ 22 dBm minimum
Carrier Spurious	-60 dBc
Noise Figure	15 dB max. @ 0 dB attenuation

### Typical LNB Characteristics (MBT-4000B)

LNB Input Frequency By Model	
C-Band Input Frequency	3.625 to 4.200 GHz
Noise Figure	≤ 35°K.
Ku-Band Input Frequency	10.95 to 11.70 GHz
Options	11.70 to 12.20 GHz 12.25 to 12.75 GHz
Noise Figure	1.0 dB maximum
Output Frequency Range	950 to 2000 MHz (depends on RF band)

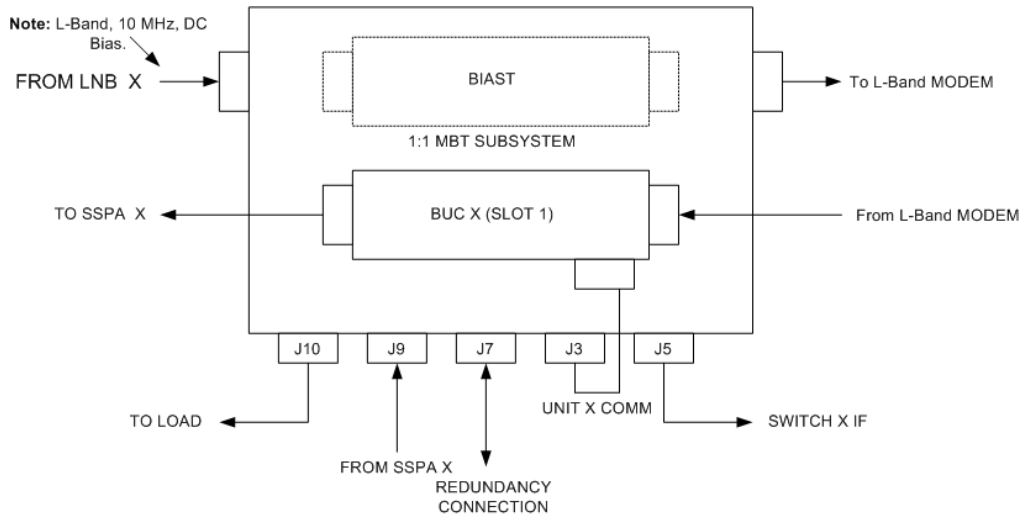

**MBT-4000B System**



2114 West 7<sup>th</sup> Street  
 Tempe, AZ 85281 USA  
 Phone +1.480.333.2200  
 Email sales@comtechefdata.com  
 www.comtech.com

See Comtech's Patents and Patents Pending at <http://patents.comtechefdata.com>

Comtech reserves the right to change specifications of products described in this document at any time without notice and without obligation to notify any person of such changes. Information in this document may differ from that published in other Comtech documents. Refer to the website or contact Customer Service for the latest released product information.

8/30/2022  
 © 2022 Comtech